

Electronics / Electrical Engineering

Thermography Systems for Use in Development and Production

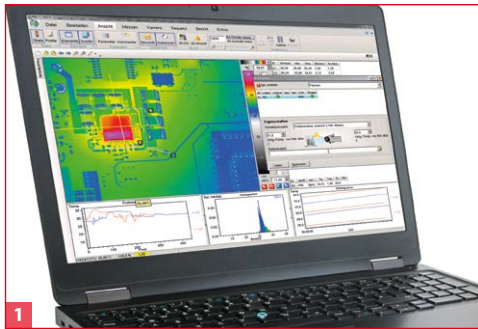

1

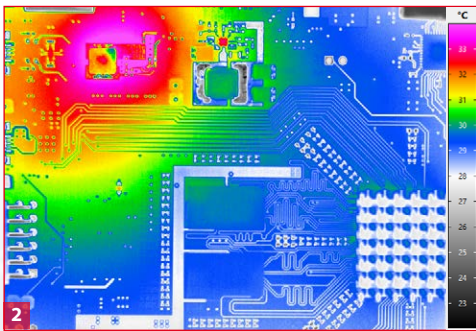

2

- 1) Thermographic software IRBIS® 3
- 2) Thermal image of a circuit board

INFRA^TEC.

- Detection of hotspots and atypical temperature distributions
- Locating errors such as increases in resistance, lack of thermal connections and soldering defects
- Visualisation of temperature differences less than 1 mK
- Precise resolution of structure sizes of only a few micrometres
- Use of infrared cameras with image formats up to 5.2 Megapixels
- Use of test methods such as active thermography



www.InfraTec.eu

www.InfraTec-infrared.com

*Innovative Measurement
Technology from Germany*

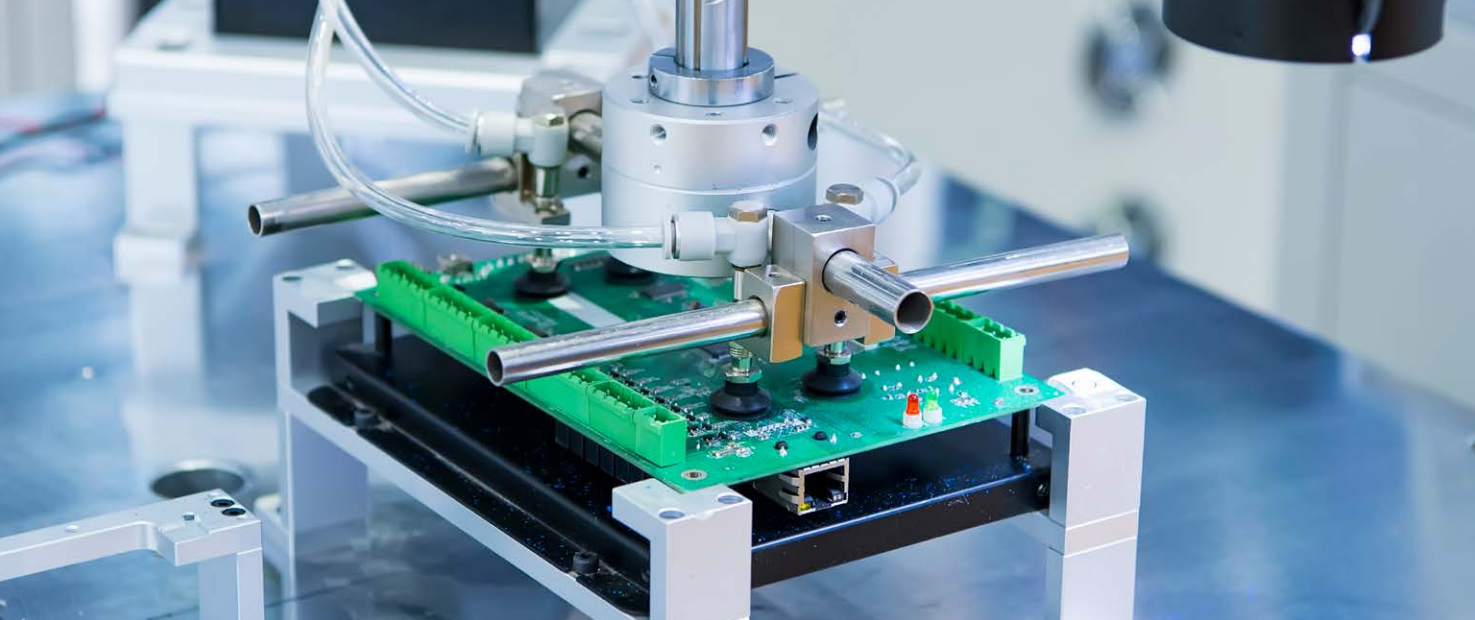

Infrared Thermography in Electronics and Electrical Engineering

Infrared thermography as an imaging method is used in electronics and electrical engineering for the **contactless measurement of surface temperatures of a large area**. With the help of this optical method, **numerous measurement points can be recorded simultaneously and with high temporal resolution**. The thermographic temperature measurement is completely **non-reactive and does not influence the HF impedance of the test object or the heat dissipation of the same**. This results in the reliable avoidance of corresponding measurement errors. Users can thus quickly and efficiently record the temperature distribution and its temporal course on complex assemblies.

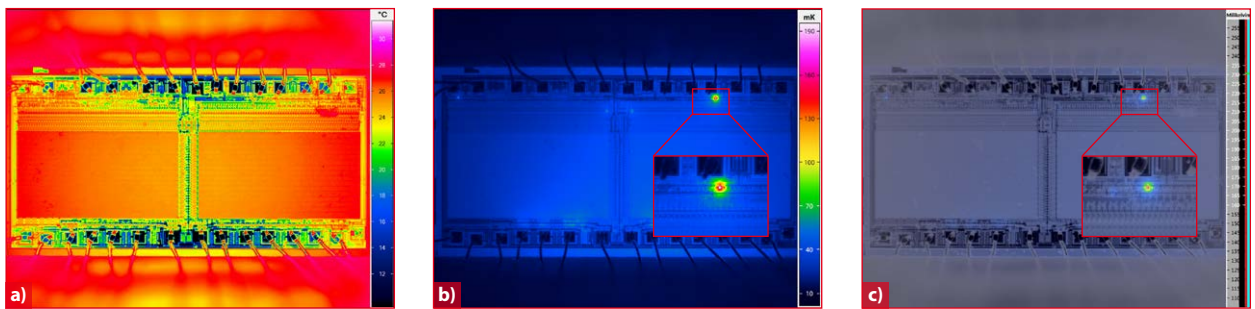

By means of lock-in analysis procedure of InfraTec's IRBIS® 3 active, errors that only cause mK or μ K deviations can be reliably detected and assigned to their location: a) Classical thermal imaging – defect not detectable; b) Amplitude image – analysis by Lock-in Thermography; c) Combination of live and amplitude image

Wide Range of Applications

Thermographic analyses of electronic components and assemblies already play an important role in the development of first prototypes. During each development step they provide important conclusions for the **optimisation of thermal management** and the design of complex electronic assemblies. In electronics production, thermographic temperature measurement is used for **quality assurance**. Thermography offers decisive advantages both in the setting of critical technological parameters and their permanent monitoring, as well as in the **in-line inspection** of products and their **final functional testing**.

The following can be identified, for example:

- Hot spots and atypical temperature distributions on circuit boards, integrated circuits and multichip modules
- Increased contact resistances
- Increase in resistance due to constriction of cables
- Hidden cracks in joints
- Power loss due to HF mismatch
- Faulty thermal connections of heat sinks
- Short circuits, soldering defects



How to heat up a circuit board?
Please scan the QR Code or go to
<http://bit.ly/32nacs2> and watch the video.



Reliable Localisation and Detailed Mapping of Thermal Anomalies

Thermography systems with a high geometric resolution are able to make the **smallest structures clearly visible** and, in addition, to determine their temperature distribution and temporal course exactly. By means of **special macro attachments and powerful infrared microscope lenses**, users can thermographically measure **hotspots of a few micrometres in size** on the surface of components such as semiconductor devices. With the additional use of **Solid Immersion Lenses (SIL)** mounted on the target, even smaller structure sizes can be detected.

Smaller and at the same time more powerful components are nowadays operated with ever lower supply voltages. Their lower electrical power consumption is usually accompanied by lower temperature changes. Consequently, the analysis of occurring errors requires a **measurement system with high thermal resolution**.

The determination of temperatures and temperature changes with infrared cameras can be based on two different measurement principles – **passive and active thermography**. With passive thermography, the measurement is based on the thermal energy that the object to be measured has due to the process and, if necessary, the ambient conditions. In the case of active thermography, a heat flow is generated in the object to be measured by an external energy input.

Electronic components such as integrated circuits can be actively electrically excited for this purpose. The **IRBIS® 3 active thermography software** offers complex evaluation algorithms to match this active thermography process, providing the basis for obtaining reliable results. **Temperature differences of less than 1 mK** can be precisely detected.



"Modern high-end infrared cameras have a high number of pixels, which are crucial for the recognition of details. The analysis of complex assemblies and individual components requires technology with high geometric and thermal resolution. Anyone who examines assemblies where defects cannot be localised with conventional functional tests can create comparative images of fault-free assemblies. Comparative analysis of the thermograms is then often sufficient to identify the fault. Thus, errors can be detected and eliminated in a time-efficient and simple manner."

Marian Kerze
Development infrared cameras

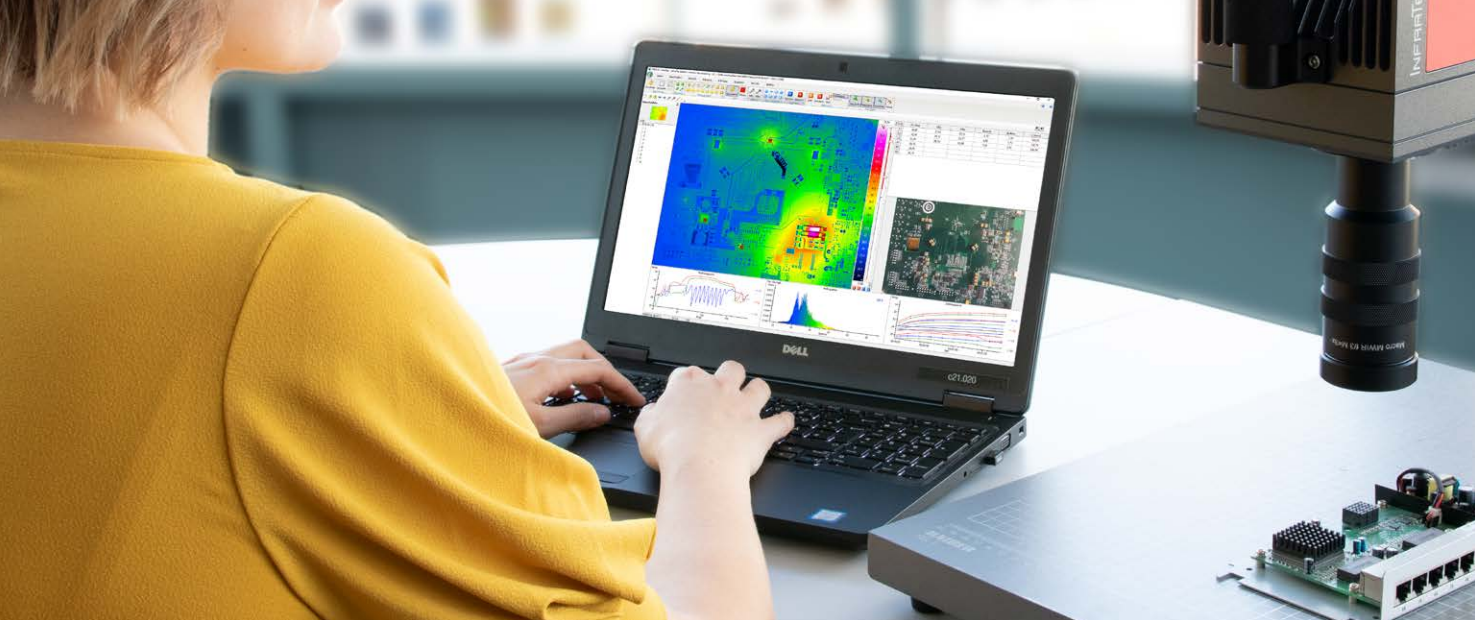

Precise Results in the Shortest Possible Time

High-speed Mode



Increase frame rate and sensitivity

Due to the binning technology, infrared cameras have two speed modes – the standard mode and the high-speed mode, in which the frame rate increases more than three times. The field of view remains constant in both modes, so the scene captured by the camera does not change. In high-speed mode, the thermal resolution also increases by a factor of two.

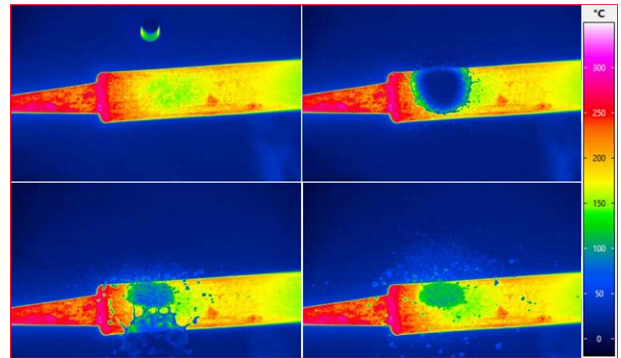

Impact of a drop of water on a soldering iron in high-speed mode

MicroScan



Quadrupling the number of pixels

Displaying measurement objects with extremely low noise and fine resolution – this is what MicroScan is for. Using this function, the native pixel number of the detector can be quadrupled. This results in thermograms of better image quality with geometric resolutions of more than 5.2 Megapixels. Each pixel in the image represents a true temperature reading, not an interpolated pixel.

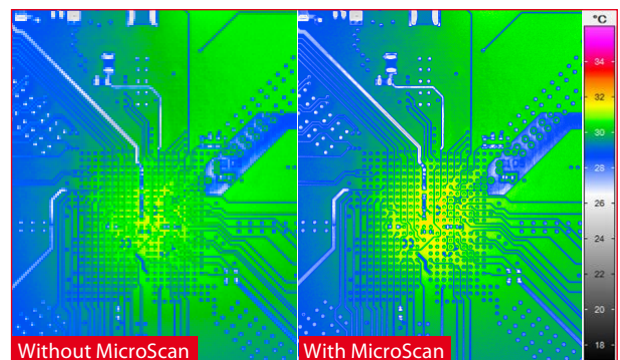

Comparative image without and with MicroScan technology

Geometrical Resolution



Efficient analysis of complex assemblies

InfraTec's infrared cameras with cooled and uncooled detectors have native resolutions up to $(1,920 \times 1,536)$ IR pixels. Spatially high-resolution thermograms ensure that components and assemblies are imaged down to the smallest detail and thus defects can be reliably detected and precisely localised.

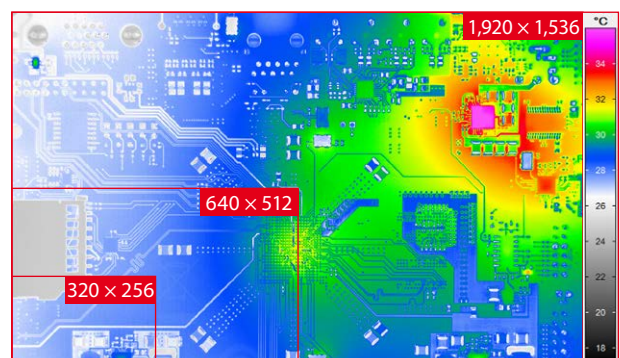

Geometrically induced measurement errors can be avoided with large detector formats

- 1 GigE Vision interface (LEMO® socket, 8-pin)
- 2 Trigger and process interface (LEMO® socket, 14-pin)
- 3 10 GigE interface



Thermal Resolution



Determination of differences of only a few millikelvin
 For detection of small temperature changes InfraTec's infrared cameras offer thermal resolutions up to < 15 mK in real-time operation. By using the Lock-in Thermography method it is possible to further increase this resolution significantly. For this purpose test objects are periodically excited and non-destructively examined for defects and irregularities.

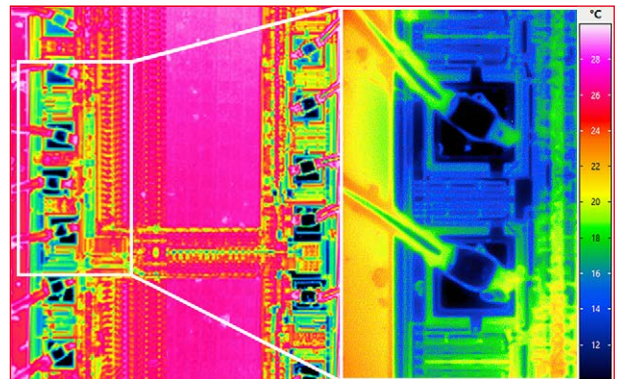

A high thermal resolution supports the noise-free and detailed imaging of measurement objects

EverSharp



Displaying measurement objects in a sharp thermal image consistently

The EverSharp function allows all objects in the image scene to be sharp. The automatic combination of thermal images with different focus positions ensures that only the sharply focused object structures are shown in the resulting thermal image.

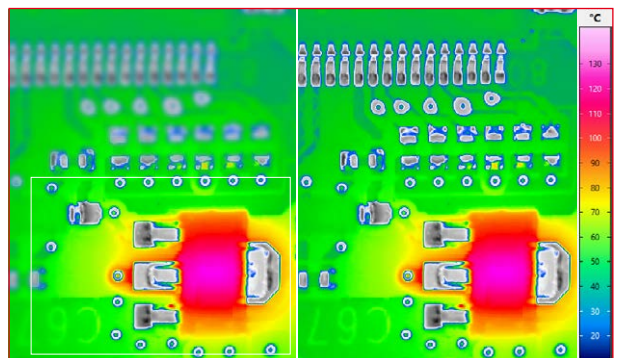

Without EverSharp function (left) only partial areas can be displayed sharply, but with this function (right) all objects can be displayed sharply

Integrated Trigger / Process Interface and Interfaces



Digitally controlling of an infrared camera and external devices

The internal trigger interface guarantees highly precise, repeatable triggering. Each of the two configurable digital inputs and outputs are used to control the camera or to generate digital control signals for external devices. In this way, for example, the operation of a printed circuit board and the interval of a measurement can be synchronised.

The selection of different camera interfaces allows the processing of analog data, such as the voltage directly through the camera and thus the insertion of this information into the thermal image data. Relevant variables can be included in the evaluations with the software, which makes it easier to draw conclusions about the causes of temperature changes.



Optimum Range of Functions for Every Task

Scalability

InfraTec offers solutions that support you from development to quality assurance in production. These include extremely versatile infrared cameras of different performance classes and spectral ranges, whose **detector formats have up to**

(1,920 × 1,536) IR pixels. In addition to **stand-alone operations**, these cameras have proven successful as components of **automated thermography systems**.



Lenses

For the precise detection of temperature distributions and local energy losses on very small targets, lenses also allow for short working distances due to their design are of great advantage. **Exchangeable standard lenses** of the infrared camera series ImageIR® can be combined with a **motor focus unit**, which is controlled via the camera operating software. It enables precise, remote and fast focusing. In addition, an **autofocus function** is available that works reliably even with low image contrasts. Several regions of interest (ROI) can be predefined for autofocus. Due to IR-transparent lens materials and

high-quality anti-reflection coatings, the infrared lenses are optimised for **different spectral ranges**. The combination of high-resolution camera technology with special **full microscope lenses** – with magnification factors $M=1.0\times$; $3.0\times$ and $8.0\times$ – produces detailed images with a pixel size up to $1.3\mu\text{m}$. Special **close-up attachments** also serve to further improve the geometrical resolution of standard lenses. They support the adaptation of the image field geometry to almost any measurement situation and guarantee best image quality.

Accessories

Often the solution of measurement and testing tasks requires the use of special equipment. For such cases InfraTec offers a wide range of high-quality accessories. If, for example, a particularly high degree of accuracy is required, a **motorised microscope stand and a two-axis positioning system** facilitate the exact adjustment of the position and the distance of the camera to the measuring object.

The positioning adjustment is performed with a step size of $0.5\mu\text{m}$ and ensures highly precise and repeatable focusing.

Further accessories:

- Solid Immersion Lenses (SIL) for microscope lenses
- IR protection windows and laser protection filters
- Memory cards, Breakout-Box, fiber optic converter

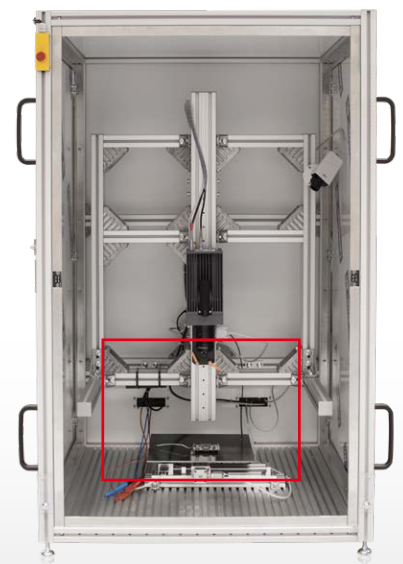
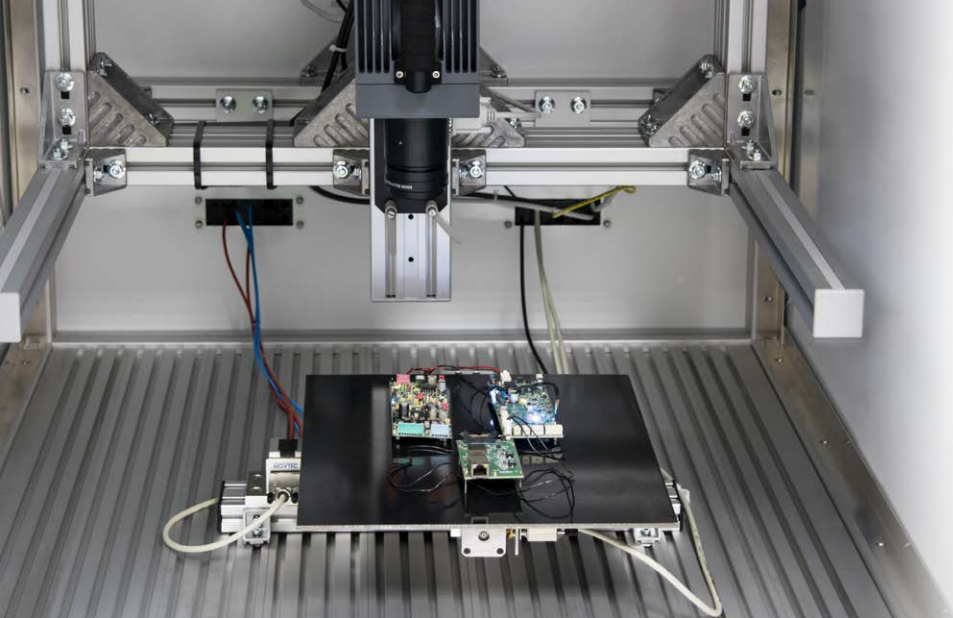

Special Software for Active Thermography

Active thermography and active electrical excitation, for example of integrated circuits, offer a reliable way of distinguishing between defective and intact structures and, in return, of detecting temperature differences in the millikelvin and microkelvin range. The **IRBIS® 3 active thermography software** is specially designed for this process. Its complex evaluation algorithms provide an excellent basis for determining reliable results.

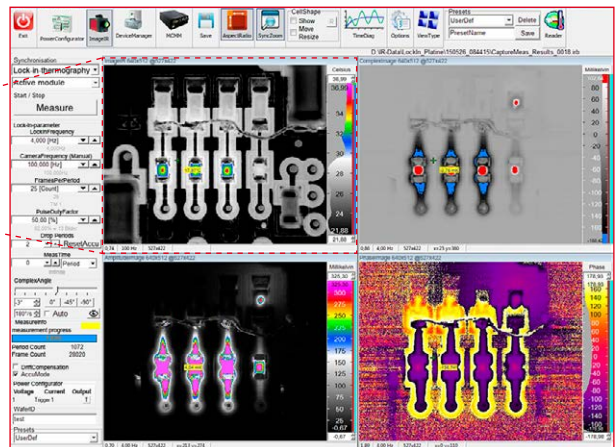
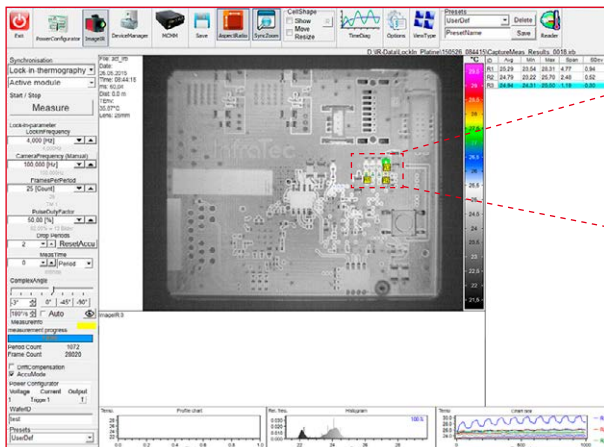

Selectable views in the IRBIS® 3 active, for example layout, time domain, amplitude and phase image

Aligned Optimally to the Application

- With the help of the **pixel-by-pixel automatic emissivity correction**, typical error sources such as interfering radiation from the environment or damping characteristics of the measuring track can be taken into account in the temperature calculation, thus reliably preventing incorrect measurements
- Overlay different views such as time domain image with the amplitude or phase image for **exact location of defects**
- Increase the excitation frequency to a multiple of the frame rate of the infrared camera in order to **sharply image rapid temperature changes with high-frequency excitation**
- In the test **management feature**, various parameter settings can be conveniently stored, clearly arranged and called up again in order to reduce preparation times and to allow measurement jobs to be run reliably under identical conditions even by different operators
- **Automatic processing and storage of large amounts of data** for the realisation of measurement periods of up to several days without user interaction
- Using a selection of different analysis methods of active thermography by means of **quotient, pulse-phase and lock-in methods**, thus ensuring individual adaptation to the respective task
- Use **LabVIEW and MATLAB interfaces** and software development kit for easy integration into existing system environments



How does the IRBIS® 3 active work?
To find out, please scan this QR code or go to <http://bit.ly/2YcUJBG> and watch the video of a test measurement

Comprehensive Equipment of Highest Quality

InfraTec offers the right components for all applications in the field of electrical engineering and electronics from simple to complex to successfully solve even the most sophisticated measurement and testing tasks. This enables the configuration of the thermographic systems, consisting of thermal imaging camera, lenses, software and accessories, to be optimally customised to the requirements.

Hardware



- High-end infrared cameras for stationary and hand-held use
- Cooled photon detectors and uncooled microbolometer detectors with up to $(1,920 \times 1,536)$ IR pixels
- Thermal resolution up to < 0.015 K, in combination with active thermography < 1 mK
- Precise and repeatable triggering
- Measurement accuracies of up to ± 1 °C or ± 1 % for exact measurement results
- Automated testing system E-LIT for electronics and semiconductor module testing using Lock-in Thermography

Lenses and Accessories

The extensive range of high-quality precision interchangeable lenses allows the field of view to be adapted to almost any measurement situation:

- Wide angle, normal and telephoto lenses
- Close-up attachments
- Microscope lenses
- Solid Immersion Lenses (SIL)

Additional to the lenses, users can choose from a wide range of accessories:

- Excitation controllers for active thermography
- Two-axis positioning systems
- X-Y measurement tables
- Motorised microscope stands

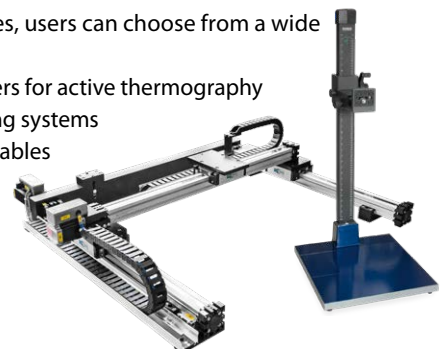

IRBIS® 3 Software



InfraTec pays special attention to the optimal interaction between the infrared camera and the software. The IRBIS® 3 thermography software contains extensive functions that support the use of passive and active thermographic methods. These include, for example, the comparison between current thermograms and a reference image as well as the display of amplitude and phase images with adjustable parameters for Lock-in Thermography. In this way, errors can be unerringly detected and clearly displayed.

Headquarters

InfraTec GmbH
Infrarotsensorik und Messtechnik
Gostritzer Str. 61 – 63
01217 Dresden / GERMANY
Phone +49 351 82876-610
E-mail thermo@InfraTec.de
Internet www.InfraTec.eu

USA office

InfraTec infrared LLC
Phone +1 844-226-3722 (toll free)
E-mail thermo@InfraTec-infrared.com
Internet www.InfraTec-infrared.com



Latest information on the internet.

© Cover: iStock.com / Squaredpixels, page 2: iStock.com / kynny

Design and specification subject to change without prior notice.

© InfraTec 03/2020 (All the stated product names and trademarks remain in property of their respective owners.)